

Quill shafts for G33CM OPTICRUISE and G33CM + IT OPTICRUISE for SCANIA gearbox with pneumatic switch kit

We are pleased to inform you that new quill shafts are now available for SCANIA G33CM OPTICRUISE and G33CM+IT OPTICRUISE gearbox series and its pneumatic engagement kit. This kit has been designed in order to be an integration to the SCANIA original components, which allows the engagement feedback by interacting with the ECU. The new quill shafts allow the installation of a wide range of rear mounting PTO's and to take advantage of external lubrication in case of heavy duty applications.

Ordering code: **09302880337** G33CM + IT OPTICRUISE
09302880346 G33CM OPTICRUISE

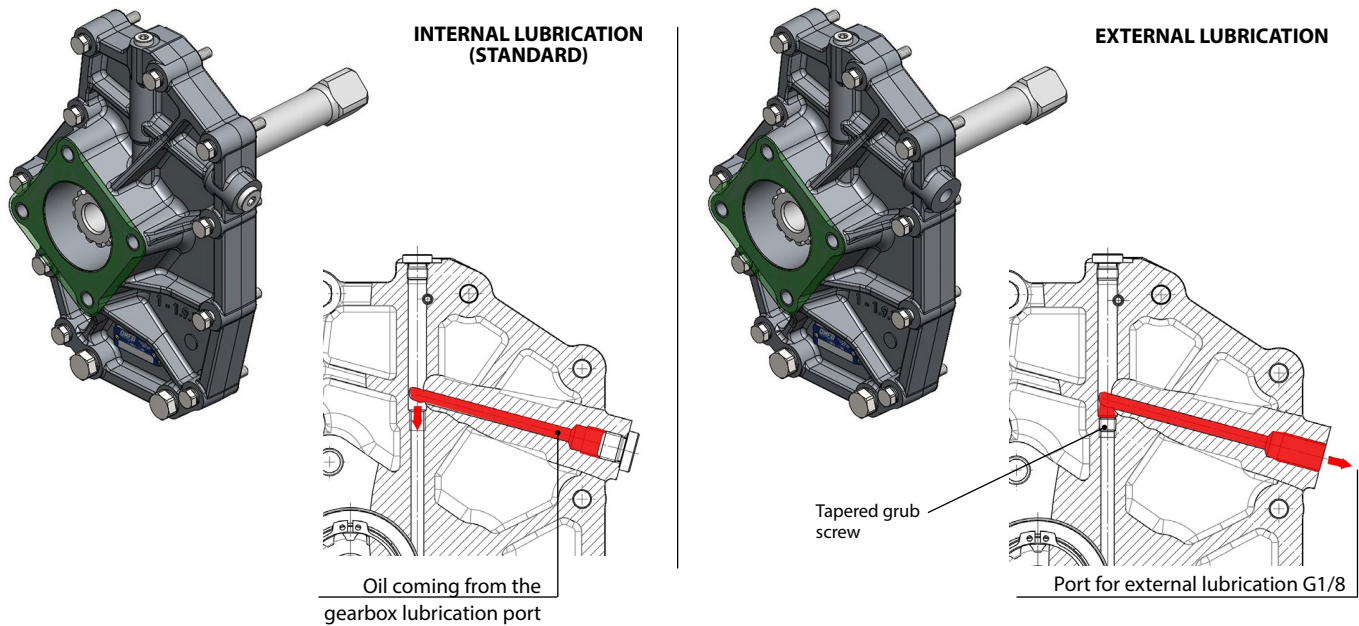

Dimensions

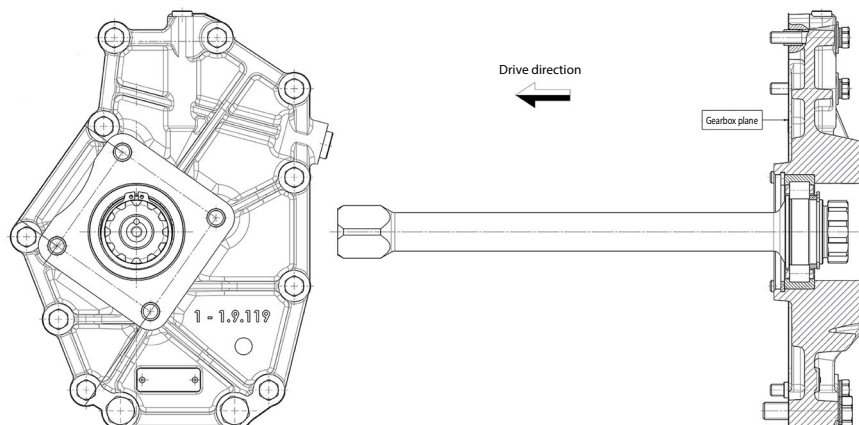

Link:
[Data sheet](#)

The pneumatic kit includes an integration system for the original Scania PTOs sensor installed on G33/G25 gearboxes. The kit consists of:

- an engagement solenoid valve;
- a pneumatic piston integrated with the original Scania sensor that simulates the PTO transition engaged and disengaged;
- an electrical wiring to pick up the signals in the ECU.

This kit is designed to integrate the original SCANIA components that interface with the vehicle's ECU to provide feedback of successful engagement.

The ordering code is.

09400300205

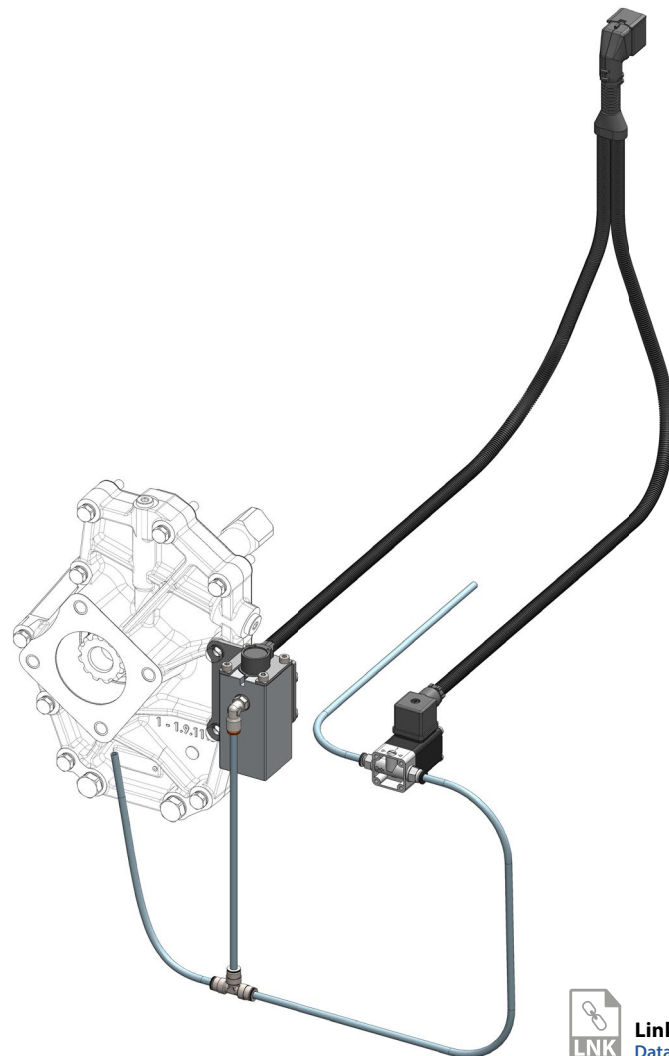

For any information you may need, please contact our export department.